

EXHAUST AIR VALVES SR-E

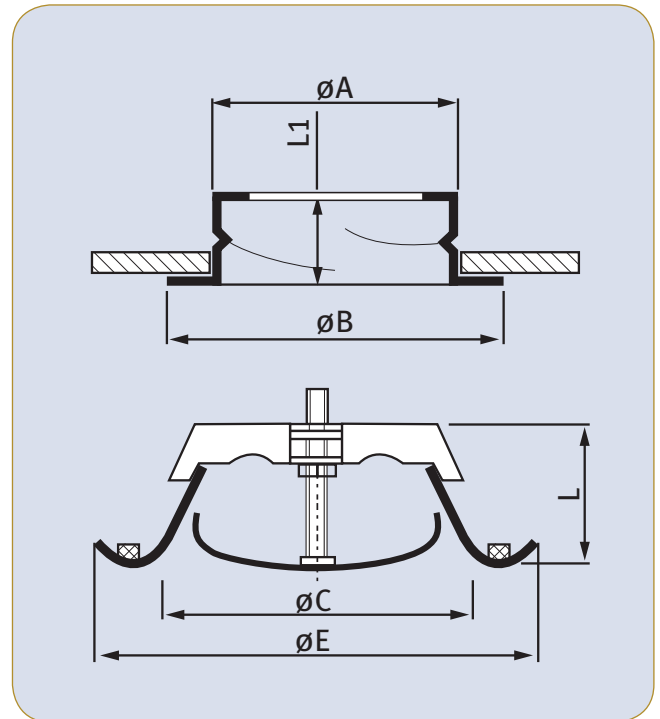

- Exhaust air valves designed for ceiling mounting on ventilation ducts
- Made of galvanized steel
- Painted white (RAL 9010)
- Easy adjustment of air flow by rotating the central part
- Blocking nut allows for setting the minimum slot
- Special design ensures low noise level
- High manufacturing quality and modern design
- Long installation flanges make it easier to connect to the system
- Quick and easy installation
- Product has certificate of the National Hygiene Institute PZH

EXHAUST AIR VALVES SR-E + INSTALLATION FLANGES KLL

Valve Dimensions	øA (mm)	øB (mm)	øC (mm)	øE (mm)	L (mm)	L1 (mm)
80	79	118	62	115	55	50
100	98	125	76	142	55	50
125	123	150	100	167	65	50
150	148	176	120	202	65	50
160	159	185	128	212	65	50
200	198	225	157	255	65	50
250	248	290	215	305	75	50

CHARACTERISTICS OF EXHAUST AIR VALVES SR-E

