



Ophangrail W 1 materiaal: sendzimir verz.						
artikelnr.	type	afmeting b x h x d (mm)	lengte (mtr.)		gewicht (kg/mtr.)	verpakking (bundel)
20001002	W 1	30/15/2,0	2		0,95	250 mtr. en per stuk



Schoor 45° 35/36 verzinkt materiaal: electrolytisch verzinkt			
artikelnr.	type	lengte L (mm)	
20013498	310	310	



Schuifmoeren, geschikt voor W 1,5 - W 1 oppervlakte: electrolytisch, verzinkt		
artikelnr.	type	afmeting l x b x h (mm)
20031008	M 8	24 x 15,5 x 5

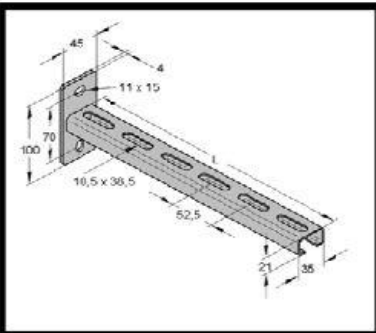

Railconsole 35/21/2,0 mm materiaal: galv. verzinkt wandplaat: 120 x 40 x 6,0 mm, gat-Ø 13 mm								
artikeinr.	lengte L (mm)	toegestane belasting*				gewicht (kg/st)	verpakking (stuk)	
		F1 (kN)	F2 (kN)	F3 (kN)	F4 (kN)			
20012053	315	1,4	0,3	0,7	0,4	0,610	1	op bestelling
20012054	420	0,5	0,1	0,3	0,1	0,850	1	op voorraad